

Tilt Table

Ideal for Rehabilitation Wards, Diagnostic Clinics doing venous testing.

The LynX tilt Table is an affordable Australian made Tilt Table offering a smooth and quiet tilt function from horizontal to +85° with infinite adjustment in between.

The unique footplate design is the only tilt table on the market which allows the patient to walk on and walk off safely when at full vertical tilt. The footplate can simply be folded away to convert the table into an Examination/Treatment Table when required.

Supplied standard with three extra wide safety straps, multi-function hand controls and heavy duty independently lockable castors.



Features

- Electric height & tilt adjustment with hand switch
- Single foldaway footplate as standard
- Optional +/-10° plantar/dorsi footplate available
- 3 x Patient safety straps supplied as standard
- Footplates can foldaway converting the tilt table into an examination table when required
- Independently operated tilt and height adjustment – can be operated at the same time or individually from any position
- Heavy duty industrial lockable castors
- 5 Year warranty on frame & electrics
- Australian designed and manufactured

Specifications

- 200kg Maximum Lifting Capacity (moving)
- 400kg Maximum Working Load (stationary)
- 600mm Minimum Height
- 1000mm Maximum Height
- 710mm Table Width
- Infinite tilt adjustment to +85°



SPECS & OPTIONS

Tilt Table

	CODE	QTY
Product Description		
LynX Tilt Table (710 wide) – Single Section	53811	
LynX Tilt Table (710 wide) – Two Section	53821	
Width Options		
770mm Width Option	-75	
Custom Width Option	6014	
Foam & Vinyl Options		
75mm Comfort Foam	6005	
Non-Stock Vinyl Option	6018	
Leather Upgrade	6008	
*please refer to our colour chart for vinyl colour options		
Nose Hole Options		
Nose Hole	6011	
Nose Hole Plug	6010	
Motor Options		
Electric Operated Backrest (2 section model only)	6031	
Footplate Options		
-/+ 10° Plantar/Dorsi Flexion Footplate	5043	
Castor Option		
Hoist Access 140mm Clearance	6028	
Rail Options		
Side Rail (Left/Right) each	5115	
Tilt Table Specific Options		
Inclination Indicator	6023	
Tilt Table Patient Strap - Additional	5048	
Table Protection		
Paper Towel Roll Holder	6017	
Extended Warranty		
10 years Frame & Electrics	7800	
Freight		
Freight charges are not included in our prices. Please contact your Healthtec representative for freight costs and options.		
Shipping Dimensions	2050mm x 850mm x 650mm	
Shipping Weight	80kg (approximately)	

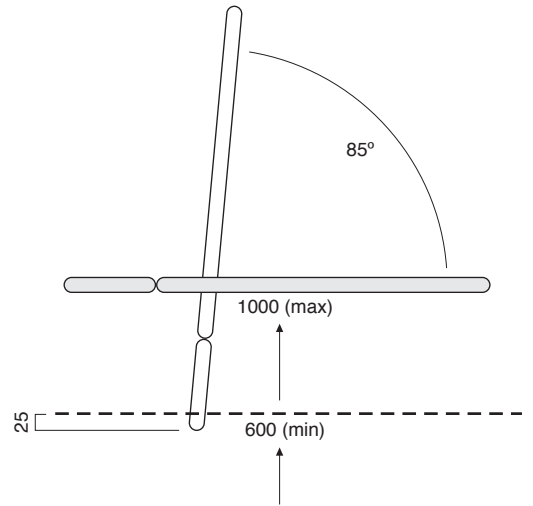
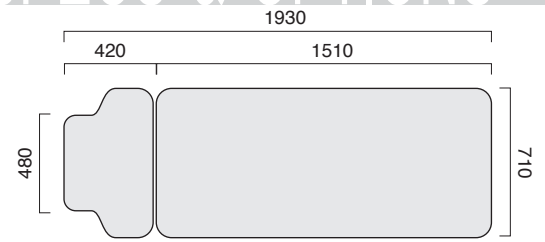

53811 Single Section

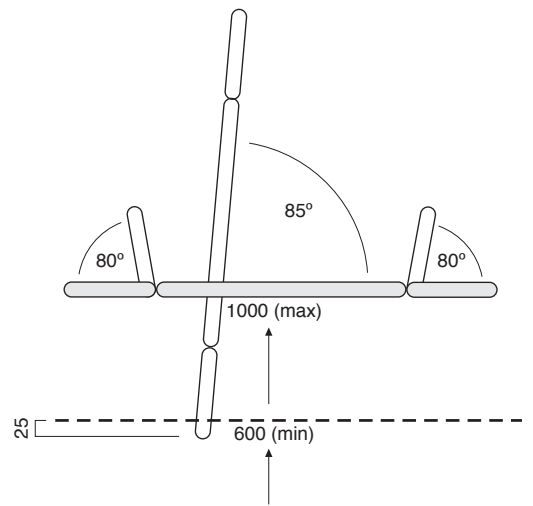
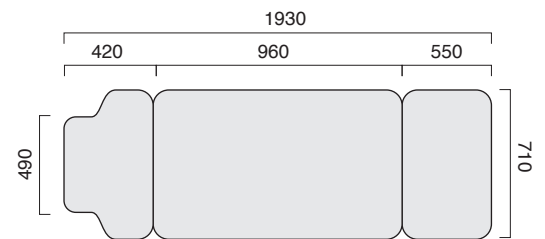

53821 Two Section