

Ultimate Bobath

Specially designed for treating patients with neurological conditions

Similar to the Neurological Bobath but with a greater lifting capacity, hoist access clearance and increased operational height range.

With a treatment area of 1200mm x 2000mm and low minimum height provides excellent access for patients with limited mobility or for wheelchair transfers.

The electric height adjustment can be quickly set at the touch of a button reducing fatigue or backstrain on the practitioner.



Features

- Electric height adjustment with footswitch
- X-Frame Lift action minimises pinch and crush points
- Heavy duty individually lockable castors
- Durable powder coated rust resistant frame
- High quality anti-microbial vinyl & CFC free foam
- 5 year warranty on frame & electrics
- Australian designed & manufactured

Specifications

- 250kg Maximum Lifting Capacity (moving)
- 400kg Maximum Working Load (stationary)
- 600mm Minimum Height
- 1000mm Maximum Height
- 1200mm Table Width
- 2000mm Table Length
- Heavy duty industrial quality lockable castors
- Available as single section or two section option*

*Two Section manual backrest adjustment +45° (electric backrest model available)

Ultimate Bobath

	CODE	QTY
Product Description		
Ultimate Bobath Table (1200 wide) – Single Section	50301	
Ultimate Bobath Table (1200 wide) – Two Section	50291	
Ultimate Bobath Table (1200 wide) – Two Section w/Powered Backrest	50271	
Width and Length Options		
Custom Width Option	6014	
Custom Length Option	6009	
Vinyl Options		
Non Stock Vinyl Option	6018	
Leather Upgrade	6008	
*please refer to our colour chart for vinyl colour options		
Headrest Options		
Nose Hole – Bobath (one hole)	6011-3	
Nose Hole – Bobath (three holes)	6011-4	
Nose Hole Plug	6010	
Castor Options		
Central Locking Castor Option (Bobath)	60372	
Foot Switch Options		
Additional Foot Switch	6020	
Additional Double Foot Switch (for powered backrest model)	6024	
Extended Warranty		
10 years Frame & Electrics	7800	
Freight		
Freight charges are not included in our prices. Please contact your Healthtec representative for freight costs and options.		
Shipping Dimensions	2200mm x 1300mm x 700mm	
Shipping Weight	120kg (approximately)	

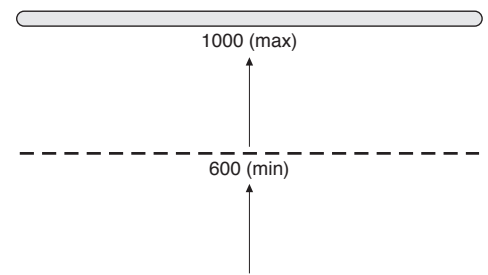
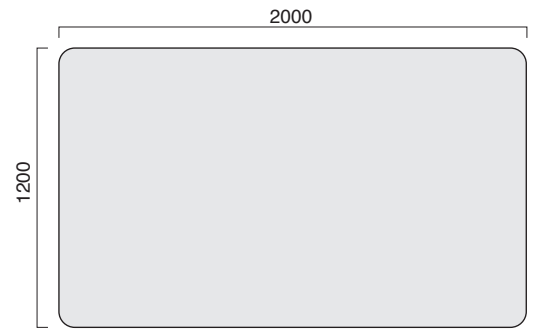

50301 Single Section

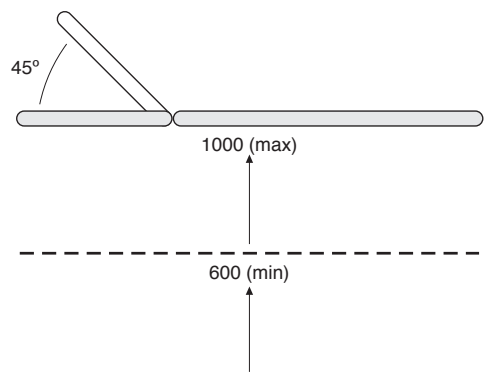
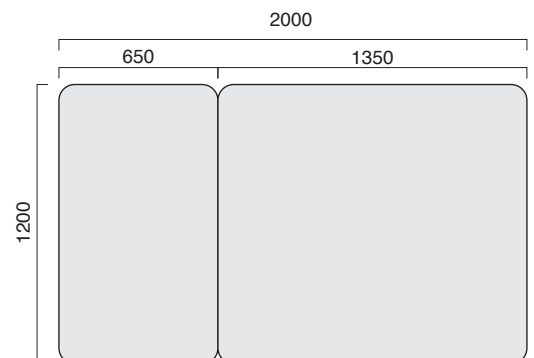

50291 Two Section

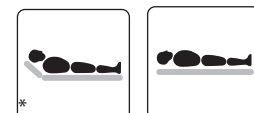

* 50291 model only

enquiries@electricaltablesolutions.com.au
www.electricaltablesolutions.com.au

1800 677 896