

Approved by



# Osteo™

The Athlegen Osteo table has been designed through consultation with the Australian Osteopathic Association (AOA). The unique, swing away prone armrest provides improved practitioner access. The Osteo long life cushioning ensures superior patient comfort and the narrower adjustable head section allows excellent practitioner access.

The Athlegen Apollo Osteopathic table is endorsed by the Australian Osteopathic Association (AOA)

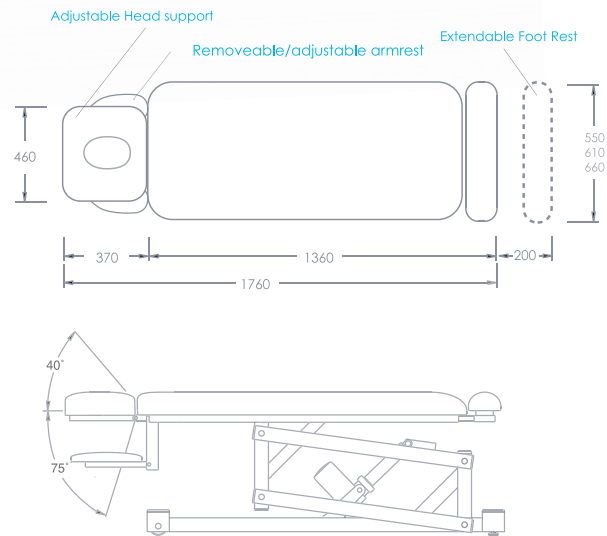

## features

- Electric power height adjustment system is driven by a commercial grade linear actuator made in Germany ensuring fast, reliable and vibration free performance.
- Prone arm rest ads to the already exceptional level of patient comfort and is removable to allow chair access
- 8 pivot lifting arm mechanism, super strong with self lubricating nylon bushes to ensure smooth and quiet operation.
- Firm Osteo cushioning designed especially for osteopathic treatments- foam construction incorporates firm edge technology.
- High quality protective coated vinyl with oil resistant properties; durable with a soft and comfortable feel.
- Narrowed, adjustable angle head support allows excellent practitioner access during treatments.
- Concealed wheels with adjustable floor levellers ensure a solid treatment platform.
- Durable powder coated rust resistant frame.
- Heavy duty stainless steel footswitch
- Built to last with very low maintenance.

## specifications

### Maneuverability

Concealed wheels with floor levelling adjustment.

### Covering

PVC tested to AS 1441.11, AS 1530.3, AS 4088.1

### Cushioning

CFC free, polyurethane foam

### Frame

Powder coated, rust resistant steel frame

### Maximum working height

990mm

### Minimum working height

480mm

### Maximum working load

175kg

### Power requirements

240 VAC @ 3.4 AMPS

### Table Length

Length with extendable foot rest (in retracted position) 1760mm  
Length with extendable foot rest (in the fully extended position) 1960mm

### Shipping dimensions

1900mm x 800mm x 800mm

### Shipping weight

125kg

### Warranty

Australia 5 years structural and 3 years motor. Extended warranty available. Other countries upon request.



enquiries@electricaltablesolutions.com.au  
www.electricaltablesolutions.com.au

1800 677 896